



ZIMMER BIOMET

Your progress. Our promise.®



Cervical Solutions

Vista[®]-S

Fusion Device

Surgical Technique Guide

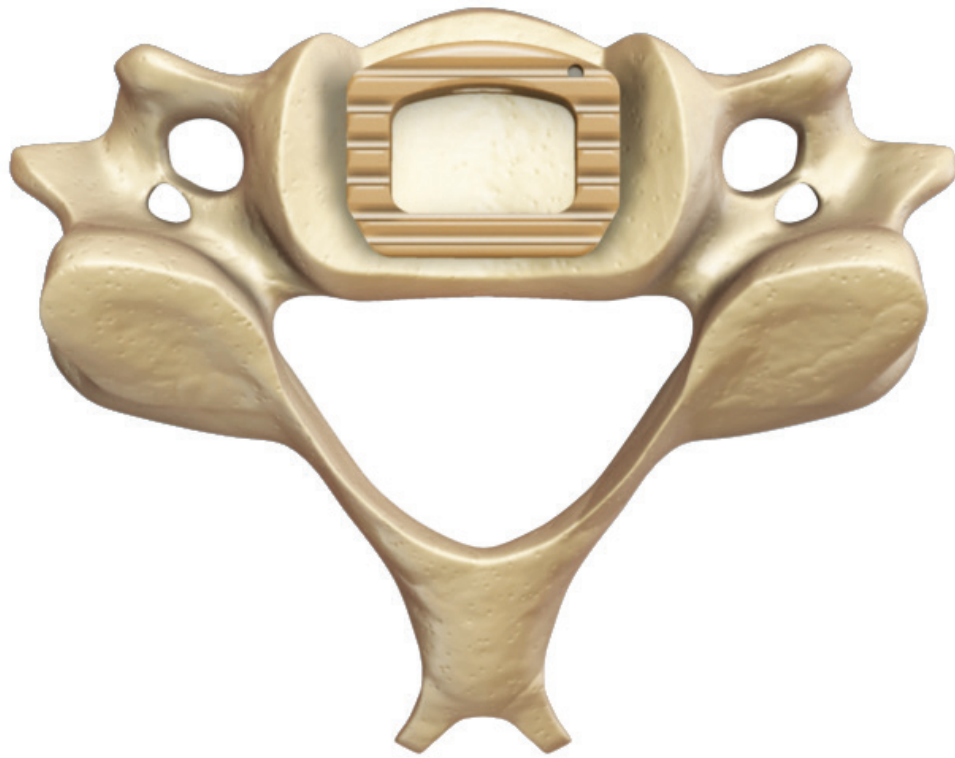

The Vista-S Fusion Device is a load-sharing, radiolucent spacer made of PEEK-OPTIMA® that accommodates varying patient anatomy in the cervical spine.

TABLE OF CONTENTS

Overview	4
Preoperative Planning and Patient Positioning	5
Surgical Approach	6
Implant Insertion Options	8
Implant Positioning	11
Vista-S Implant Sizes	13
Mergence®-S Instruments	14
Kit Contents	15
Important Information on the Vista-S Fusion Device	21

Zimmer Biomet Spine does not practice medicine. This technique was developed in conjunction with health care professionals. This document is intended for surgeons and is not intended for laypersons. Each surgeon should exercise his or her own independent judgment in the diagnosis and treatment of an individual patient, and this information does not purport to replace the comprehensive training surgeons have received. As with all surgical procedures, the technique used in each case will depend on the surgeon's medical judgment as the best treatment for each patient. Results will vary based on health, weight, activity and other variables. Not all patients are candidates for this product and/or procedure.

VISTA-S OVERVIEW

Vista-S Device implants are available in six footprints: 11 mm × 11 mm, 11 mm × 14 mm, 14 mm × 14 mm, 13 mm × 16 mm, 14 mm × 18 mm and 15 mm × 20 mm. All six sizes are available in vertical heights of 4 mm to 12 mm, in 1 mm increments, except the 11 mm × 11 mm footprint which is offered from 4 mm to 10 mm. The height is measured from the posterior (shortest) aspect of the device. In addition, the implants are offered in a 7° included angle option and a 0° included angle option to help maintain the natural contour of the spine. The Vista-S Device has a central hole extending in the superior-inferior direction for placement of autogenous bone graft.

The device also has a small slot on its anterior face for mating with its insertion instrument. The Vista-S Device is manufactured wholly from unfilled PEEK-OPTIMA® LT1. Due to its radiolucent nature, three radiopaque markers made of tantalum are incorporated into the device to indicate the nose end and the superior and inferior corners of the opposite end for use in postoperative monitoring of device position. The superior and inferior surfaces of the device have a textured surface to provide increased stability. The implants are intended for single use only and must not be reused under any circumstance.



PREOPERATIVE PLANNING AND PATIENT POSITIONING

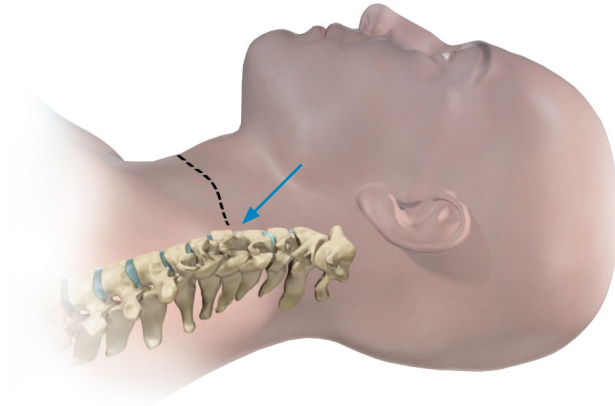

Figure 1
Identify vertebral level

STEP 1

- Preoperatively, the surgeon must identify the proper intervertebral level to fuse using diagnostic techniques such as radiographs, magnetic resonance imaging (MRI), myelography, discography, patient history and physical examination.
- Place the patient in a supine position. Support the posterior cervical spine to maintain normal lordosis and choose a right- or left-sided approach. Identify the symptomatic level and make a skin incision to the corresponding pathology.

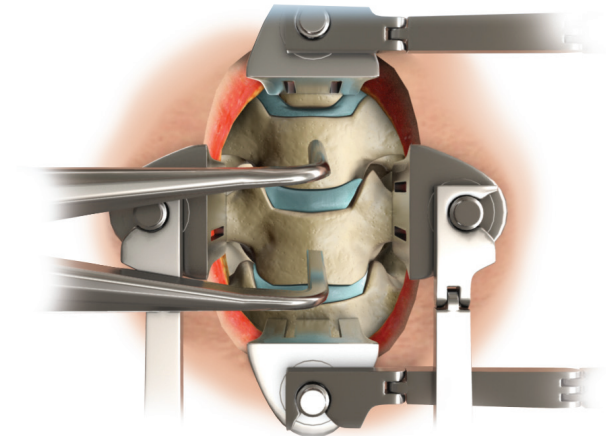

Figure 2
Exposure and location

STEP 2

- The anterior cervical anatomy is exposed in the standard fashion by identifying a dissection plane between the trachea and esophagus. Exposure is then held in place utilizing self-retaining retractors.
- The proper level is confirmed using a needle as a marker and fluoroscopy imaging. A vertebral distractor can then be placed through the open incision in the adjacent vertebrae to the discectomy.

SURGICAL APPROACH

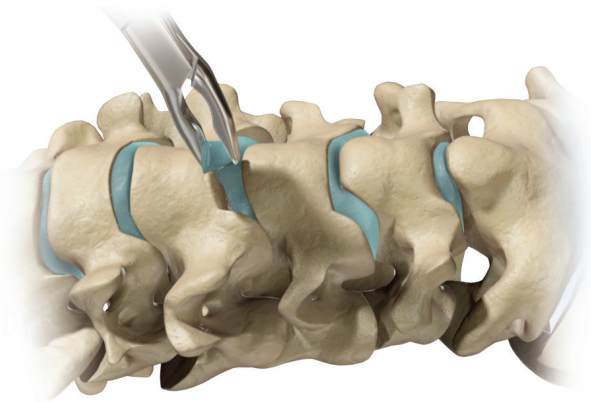

Figure 3
Discectomy

STEP 3

- Perform a standard cervical discectomy and decompression by resecting the anterior longitudinal ligament over the corresponding vertebrae. Remove the anterior osteophytes followed by the anterior portion of the annulus fibrosis. Make a window corresponding to the size of the implant. Remove the intervertebral disc out to the uncovertebral joints using general instrumentation such as curettes or rongeurs. Distract the disc space. A caspar distractor is recommended for the distraction.

Caution: Great care should be taken to ensure that all exposed blood vessels and nerves are properly retracted prior to the discectomy to avoid unintended contact with the curettes and rongeurs.

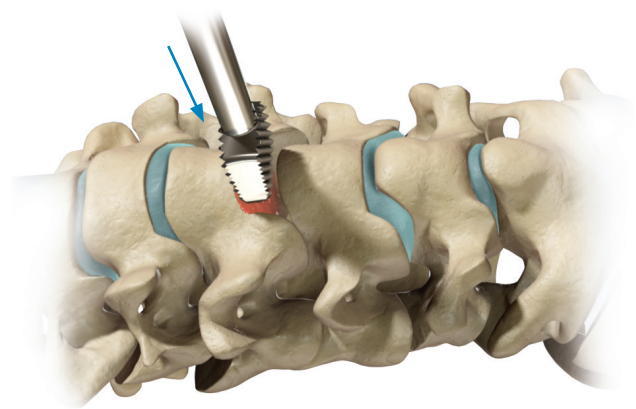

Figure 4
Endplate preparation

STEP 4

- Complete a neural decompression by trimming large posterior osteophytes (if present). Prepare the endplates by using the Mergence-S size-specific rasps, standard curettes or burrs. Remove a minimal amount of the cartilaginous endplates to create a flat surface of bleeding bone.

Note: Fluoroscopy may be used to monitor the depth of the rasp intraoperatively.

Caution: Using excessive force with the instrumentation can inadvertently rupture the posterior annulus or damage the vertebral endplates. Removal of the entire endplate can weaken the vertebral construct and may result in subsidence.

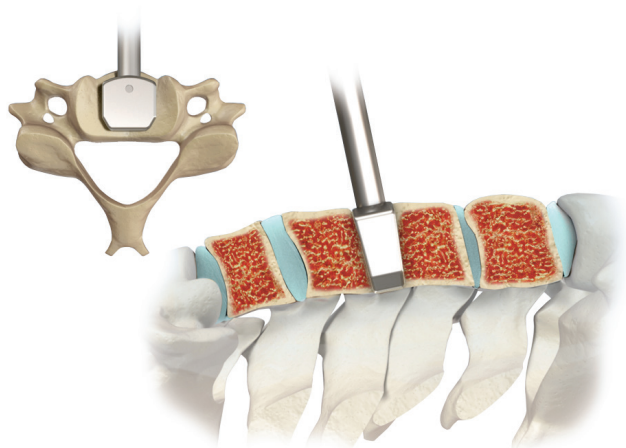

Figure 5
Implant selection

STEP 5

- Determine the implant size by measuring the disc space using the Mergence-S provisionals (trials). Insert a provisional and select the size that sufficiently fits the disc space. The proper provisional will tension the soft tissue crossing that selected disc space. Proper tension is determined by the amount of force necessary to fully seat the provisional. If the provisional seats without force, it is too small. Continue increasing the provisional's size until force is necessary to fully seat the provisional.

Note: Provisionals precisely match the dimensions of the Vista-S implants.

In 1993, an et al. used cadaver studies to establish the optimal thickness for Smith-Robinson type cervical fusion grafts. They concluded that the ideal thickness is approximately 2 mm greater than the preoperative measured disc height.

Caution: *If the provisional used within the disc space is solidly engaged and difficult to realign laterally when the proper position has been obtained within the disc space, consider implanting a device 1 mm smaller than the provisional being used.*

IMPLANT INSERTION OPTIONS

Select an implant inserter to hold the device for final placement into the disc space.

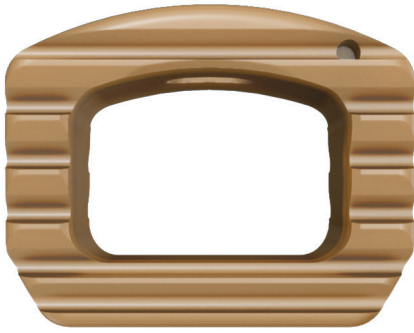

Figure 6
Bone grafting

STEP 6

- The hole in the center of the implant must be filled with autogenous bone harvested from the iliac crest.

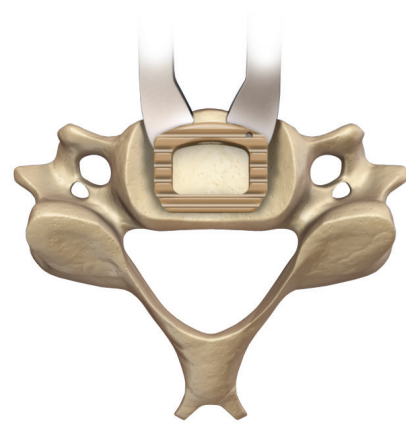

Figure 7
Lateral inserter

STEP 7: OPTION 1

- Ensure that the lateral grasping inserter is engaging the anterior convex edge of the device by evaluating the implant's geometry carefully. This inserter has a flat bar at the proximal end to facilitate impaction.

Note: The lateral grasping inserter is not compatible with the 06-101-01041, 06-101-02041, 06-102-0X041, 06-101-01051, 06-101-02051, 06-102-0X051, 06-102-0X061, 06-10X-04XX1, 06-10X-05XX1 and 06-10X-06XX1 implants.

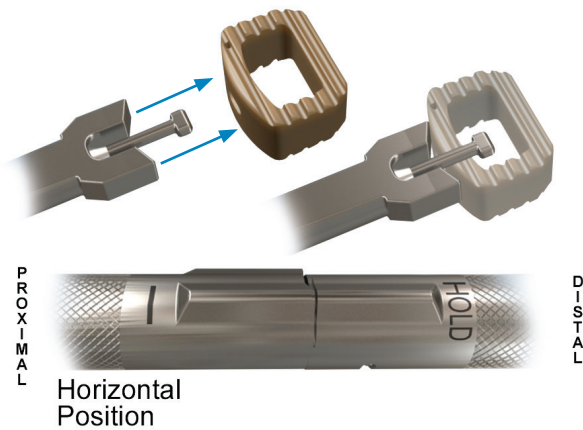

Figure 8
Central rotating inserter

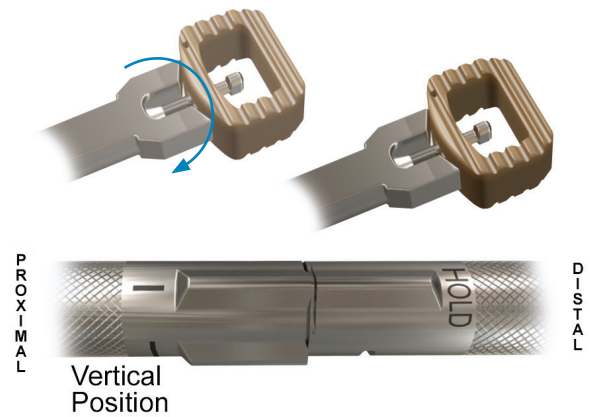

Figure 9
Inserter positioning

STEP 7: OPTION 2

- Insert the tab of the Mergence-S central rotating inserter into the slot located on the anterior convex face of the device.
- When the proximal ridge is lined up with the distal ridge and the laser marking on the central rotating inserter is in the horizontal position, the tab of the inserter is in position to place or remove the implant from the inserter.

Note: **Figure 8** shows the tab in a horizontal position, which allows for placement and removal of the implant.

- Hold the device on the distal end of the inserter. At the same time, rotate the proximal end of the inserter clockwise until the vertical ridge is aligned with the distal ridge.
- When the proximal ridge is lined up with the distal ridge and the laser marking is in the vertical position, the tab is in position to secure the implant to the inserter.

Note: **Figure 9** shows the tab in a vertical position, which allows for securing the device onto the inserter.

IMPLANT INSERTION OPTIONS (Continued)

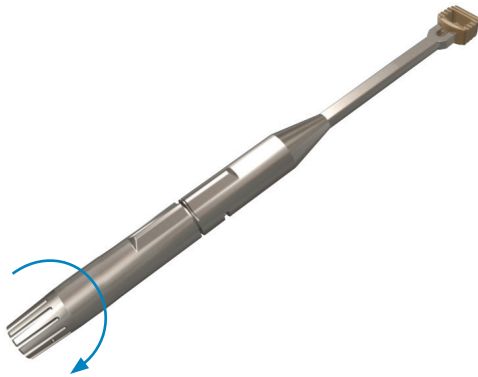

Figure 10
Securing central rotating inserter

STEP 7: OPTION 2 (Continued)

- Turn the knob clockwise until the device is secure on the inserter. The implant can be placed into the space with the inserter.
- To remove the inserter from the device, hold the proximal end of the inserter securely and turn the knob counterclockwise until a stop is reached. Hold the distal end of the inserter, and at the same time, rotate the proximal end counterclockwise until a stop is reached. Pull the inserter away from the implant while keeping the inserter parallel to the device.

Caution: Care should be taken when inserting the implant into the disc space to avoid damaging anatomy, implants or instruments.

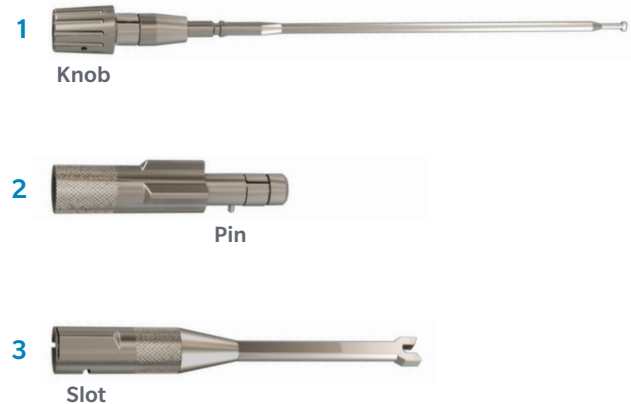

Figure 11
Central rotating inserter disassembly

Central Rotating Inserter Disassembly

- Hold the distal end of the inserter (component **3**) and rotate the proximal end (component **2**) clockwise until a stop is reached.
- Pull the proximal end away from the distal end.
- Pull the knob away from the proximal end.
- Do not disassemble the inserter any further.
- Clean and sterilize the instrument per the instrument processing instructions found in the Vista-S Fusion Device package insert (PI 043).

Central Rotating Inserter Reassembly

- Slide the distal end of component **1** into the proximal end of component **2** until the knob meets the proximal end of component **2**. Apply force if necessary.
- Slide the distal end of the assembled components **1** and **2** into the proximal end of component **3** while aligning the pin on component **2** with the slot on component **3**. Push them together until the pin reaches the end of the slot.

IMPLANT POSITIONING

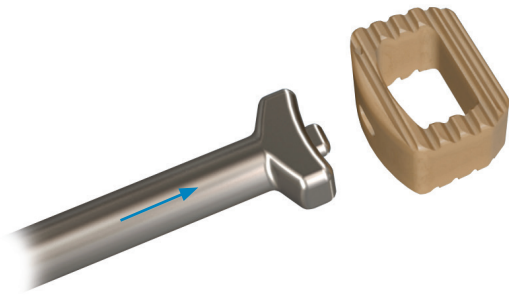

Figure 12
Final implant positioning

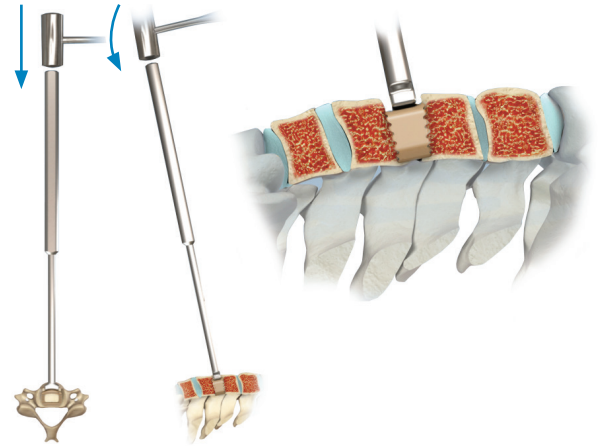

Figure 13
Tamp positioning

STEP 8

- It may be necessary to use a Mergence-S tamp for final implant seating. The concave surfaces of the tamps match the convex anterior wall of the device. It may be necessary to tap moderately on the tamp to fully seat the implant posteriorly. Tapping on the device should move the implant posteriorly. If no motion occurs, remove the device and check for an obstruction of bone or a narrow posterior opening.

Note: For implants 06-101-01041, 06-101-02041, 06-102-0X041 and 06-102-0X051, the central rotating inserter should be used for final implant positioning.

Tamp Options

Central tamp: insert the tab into the slot on the anterior surface of the device to guide the direction of insertion.

General tamp: the concave surface of the general tamp is designed to match the convex anterior wall of the device.

Corner tamp: the corner tamp may be used for lateral or rotational positioning.

Caution: The central tamp, general tamp and corner tamp are not compatible with the 06-101-01041, 06-101-02041, 06-102-0X041 and 06-102-0X051 implants.

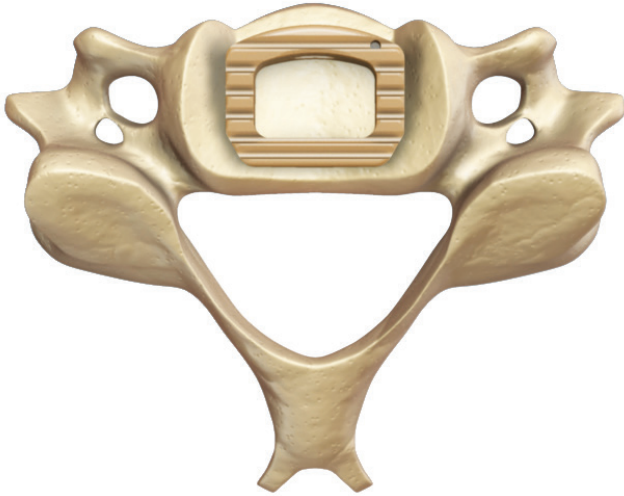

Figure 14
Position confirmation

STEP 9

- Final placement of the implant should be slightly posterior to the anterior aspect of the vertebral bodies. Lateral and A/P radiographs may be taken to assure proper implant placement.

Caution: *If difficulty inserting the Vista-S Device is encountered, do not vigorously tap on the implant. Excessive force on the implant may deform or damage the instrument, implant or anatomy. Rather, remove the implant and check for an impediment. Additional endplate preparation may be required.*

Supplemental Fixation

After implantation, anterior or posterior supplemental fixation must be used. Only titanium alloy (ASTM F-136) systems should be used.

Implant Removal or Revision

Should removal or revision of the device be determined necessary, an osteotome can be used at the interface between the bone and both superior and inferior faces of the implant. This effectively cuts the fused column of bone at the level of the boundaries of the implant. Once the fused column is completely cut, a forceps can be used to remove the implant from the space. This may be done under slight distraction. For a revision, follow the standard surgical technique.

VISTA-S IMPLANT SIZES

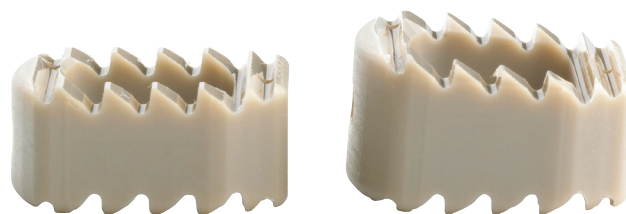

LENGTH × WIDTH	HEIGHT	ANGLE
11 mm × 11 mm	4 mm	0°, 7°
11 mm × 11 mm	5 mm	0°, 7°
11 mm × 11 mm	6 mm	0°, 7°
11 mm × 11 mm	7 mm	0°, 7°
11 mm × 11 mm	8 mm	0°, 7°
11 mm × 11 mm	9 mm	0°, 7°
11 mm × 11 mm	10 mm	0°, 7°
11 mm × 14 mm	4 mm	0°, 7°
11 mm × 14 mm	5 mm	0°, 7°
11 mm × 14 mm	6 mm	0°, 7°
11 mm × 14 mm	7 mm	0°, 7°
11 mm × 14 mm	8 mm	0°, 7°
11 mm × 14 mm	9 mm	0°, 7°
11 mm × 14 mm	10 mm	0°, 7°
11 mm × 14 mm	11 mm	0°, 7°
11 mm × 14 mm	12 mm	0°, 7°
14 mm × 14 mm	4 mm	0°, 7°
14 mm × 14 mm	5 mm	0°, 7°
14 mm × 14 mm	6 mm	0°, 7°
14 mm × 14 mm	7 mm	0°, 7°
14 mm × 14 mm	8 mm	0°, 7°
14 mm × 14 mm	9 mm	0°, 7°
14 mm × 14 mm	10 mm	0°, 7°
14 mm × 14 mm	11 mm	0°, 7°
14 mm × 14 mm	12 mm	0°, 7°

LENGTH × WIDTH	HEIGHT	ANGLE
13 mm × 16 mm	4 mm	0°, 7°
13 mm × 16 mm	5 mm	0°, 7°
13 mm × 16 mm	6 mm	0°, 7°
13 mm × 16 mm	7 mm	0°, 7°
13 mm × 16 mm	8 mm	0°, 7°
13 mm × 16 mm	9 mm	0°, 7°
13 mm × 16 mm	10 mm	0°, 7°
13 mm × 16 mm	11 mm	0°, 7°
13 mm × 16 mm	12 mm	0°, 7°
14 mm × 18 mm	4 mm	0°, 7°
14 mm × 18 mm	5 mm	0°, 7°
14 mm × 18 mm	6 mm	0°, 7°
14 mm × 18 mm	7 mm	0°, 7°
14 mm × 18 mm	8 mm	0°, 7°
14 mm × 18 mm	9 mm	0°, 7°
14 mm × 18 mm	10 mm	0°, 7°
14 mm × 18 mm	11 mm	0°, 7°
14 mm × 18 mm	12 mm	0°, 7°
15 mm × 20 mm	4 mm	0°, 7°
15 mm × 20 mm	5 mm	0°, 7°
15 mm × 20 mm	6 mm	0°, 7°
15 mm × 20 mm	7 mm	0°, 7°
15 mm × 20 mm	8 mm	0°, 7°
15 mm × 20 mm	9 mm	0°, 7°
15 mm × 20 mm	10 mm	0°, 7°
15 mm × 20 mm	11 mm	0°, 7°
15 mm × 20 mm	12 mm	0°, 7°

MERGENCE-S INSTRUMENTS

The Mergence-S Spinal Instrumentation Platform is designed to aid in the implantation of the Vista-S Fusion Device. The Smith-Robinson surgical technique is used with standard instruments, except those specifically related to the sizing and insertion of the Vista-S Fusion Device. Provisionals and rasps are provided to assist in the measurement and preparation of the implant space.



Lateral Grasping Insertor	PART NUMBER
	96-106-00001



Central Rotating Insertor	PART NUMBER
	96-106-30001



General Tamp	PART NUMBER
	96-105-00002



Corner Tamp	PART NUMBER
	96-105-20001



Central Tamp	PART NUMBER
	96-105-10001



Provisionals and Rasps*

LENGTH × WIDTH	ANGLE	COLOR
11 mm × 11 mm	7°	Blue
11 mm × 11 mm	0°	White
11 mm × 14 mm	7°	Yellow
11 mm × 14 mm	0°	Green
14 mm × 14 mm	7°	Red
14 mm × 14 mm	0°	Black
13 mm × 16 mm	7°	Red/Black
13 mm × 16 mm	0°	Yellow/Red
14 mm × 18 mm	7°	Black/Green
14 mm × 18 mm	0°	Yellow/Green
15 mm × 20 mm	7°	Black/Yellow
15 mm × 20 mm	0°	Red/Green

*Available in multiple sizes to assist in the measurement and preparation of the implant space. Color coded for easy identification.

VISTA-S KIT CONTENTS

Vista-S 11 mm × 11 mm, 7° Implant Kit 07.01443.401

DESCRIPTION	PART NUMBER
Angled Device, 11 mm × 11 mm × 4 mm, 7°	06-401-01041
Angled Device, 11 mm × 11 mm × 5 mm, 7°	06-401-01051
Angled Device, 11 mm × 11 mm × 6 mm, 7°	06-401-01061
Angled Device, 11 mm × 11 mm × 7 mm, 7°	06-401-01071
Angled Device, 11 mm × 11 mm × 8 mm, 7°	06-401-01081
Angled Device, 11 mm × 11 mm × 9 mm, 7°	06-401-01091
Angled Device, 11 mm × 11 mm × 10 mm, 7°	06-401-01101

Vista-S 11 mm × 11 mm, 0° Implant Kit 07.01444.401

DESCRIPTION	PART NUMBER
Parallel Device, 11 mm × 11 mm × 4 mm, 0°	06-402-01041
Parallel Device, 11 mm × 11 mm × 5 mm, 0°	06-402-01051
Parallel Device, 11 mm × 11 mm × 6 mm, 0°	06-402-01061
Parallel Device, 11 mm × 11 mm × 7 mm, 0°	06-402-01071
Parallel Device, 11 mm × 11 mm × 8 mm, 0°	06-402-01081
Parallel Device, 11 mm × 11 mm × 9 mm, 0°	06-402-01091
Parallel Device, 11 mm × 11 mm × 10 mm, 0°	06-402-01101

Vista-S 11 mm × 14 mm, 7° Implant Kit 07.01443.402

DESCRIPTION	PART NUMBER
Angled Device, 11 mm × 14 mm × 4 mm, 7°	06-401-02041
Angled Device, 11 mm × 14 mm × 5 mm, 7°	06-401-02051
Angled Device, 11 mm × 14 mm × 6 mm, 7°	06-401-02061
Angled Device, 11 mm × 14 mm × 7 mm, 7°	06-401-02071
Angled Device, 11 mm × 14 mm × 8 mm, 7°	06-401-02081
Angled Device, 11 mm × 14 mm × 9 mm, 7°	06-401-02091
Angled Device, 11 mm × 14 mm × 10 mm, 7°	06-401-02101
Angled Device, 11 mm × 14 mm × 11 mm, 7°	06-401-02111
Angled Device, 11 mm × 14 mm × 12 mm, 7°	06-401-02121



Vista-S 11 mm × 14 mm, 0° Implant Kit 07.01444.402

DESCRIPTION	PART NUMBER
Parallel Device, 11 mm × 14 mm × 4 mm, 0°	06-402-02041
Parallel Device, 11 mm × 14 mm × 5 mm, 0°	06-402-02051
Parallel Device, 11 mm × 14 mm × 6 mm, 0°	06-402-02061
Parallel Device, 11 mm × 14 mm × 7 mm, 0°	06-402-02071
Parallel Device, 11 mm × 14 mm × 8 mm, 0°	06-402-02081
Parallel Device, 11 mm × 14 mm × 9 mm, 0°	06-402-02091
Parallel Device, 11 mm × 14 mm × 10 mm, 0°	06-402-02101
Parallel Device, 11 mm × 14 mm × 11 mm, 0°	06-402-02111
Parallel Device, 11 mm × 14 mm × 12 mm, 0°	06-402-02121

Vista-S 14 mm × 14 mm, 7° Implant Kit 07.01445.401

DESCRIPTION	PART NUMBER
Angled Device, 14 mm × 14 mm × 4 mm, 7°	06-401-03041
Angled Device, 14 mm × 14 mm × 5 mm, 7°	06-401-03051
Angled Device, 14 mm × 14 mm × 6 mm, 7°	06-401-03061
Angled Device, 14 mm × 14 mm × 7 mm, 7°	06-401-03071
Angled Device, 14 mm × 14 mm × 8 mm, 7°	06-401-03081
Angled Device, 14 mm × 14 mm × 9 mm, 7°	06-401-03091
Angled Device, 14 mm × 14 mm × 10 mm, 7°	06-401-03101
Angled Device, 14 mm × 14 mm × 11 mm, 7°	06-401-03111
Angled Device, 14 mm × 14 mm × 12 mm, 7°	06-401-03121

Vista-S 14 mm × 14 mm, 0° Implant Kit 07.01445.402

DESCRIPTION	PART NUMBER
Parallel Device, 14 mm × 14 mm × 4 mm, 0°	06-402-03041
Parallel Device, 14 mm × 14 mm × 5 mm, 0°	06-402-03051
Parallel Device, 14 mm × 14 mm × 6 mm, 0°	06-402-03061
Parallel Device, 14 mm × 14 mm × 7 mm, 0°	06-402-03071
Parallel Device, 14 mm × 14 mm × 8 mm, 0°	06-402-03081
Parallel Device, 14 mm × 14 mm × 9 mm, 0°	06-402-03091
Parallel Device, 14 mm × 14 mm × 10 mm, 0°	06-402-03101
Parallel Device, 14 mm × 14 mm × 11 mm, 0°	06-402-03111
Parallel Device, 14 mm × 14 mm × 12 mm, 0°	06-402-03121



VISTA-S KIT CONTENTS (Continued)

Vista-S 13 mm × 16 mm, 7° Implant Kit 07.02225.401

DESCRIPTION	PART NUMBER
Angled Device, 13 mm × 16 mm × 4 mm, 7°	06-401-04041
Angled Device, 13 mm × 16 mm × 5 mm, 7°	06-401-04051
Angled Device, 13 mm × 16 mm × 6 mm, 7°	06-401-04061
Angled Device, 13 mm × 16 mm × 7 mm, 7°	06-401-04071
Angled Device, 13 mm × 16 mm × 8 mm, 7°	06-401-04081
Angled Device, 13 mm × 16 mm × 9 mm, 7°	06-401-04091
Angled Device, 13 mm × 16 mm × 10 mm, 7°	06-401-04101
Angled Device, 13 mm × 16 mm × 11 mm, 7°	06-401-04111
Angled Device, 13 mm × 16 mm × 12 mm, 7°	06-401-04121

Vista-S 13 mm × 16 mm, 0° Implant Kit 07.02228.401

DESCRIPTION	PART NUMBER
Parallel Device, 13 mm × 16 mm × 4 mm, 0°	06-402-04041
Parallel Device, 13 mm × 16 mm × 5 mm, 0°	06-402-04051
Parallel Device, 13 mm × 16 mm × 6 mm, 0°	06-402-04061
Parallel Device, 13 mm × 16 mm × 7 mm, 0°	06-402-04071
Parallel Device, 13 mm × 16 mm × 8 mm, 0°	06-402-04081
Parallel Device, 13 mm × 16 mm × 9 mm, 0°	06-402-04091
Parallel Device, 13 mm × 16 mm × 10 mm, 0°	06-402-04101
Parallel Device, 13 mm × 16 mm × 11 mm, 0°	06-402-04111
Parallel Device, 13 mm × 16 mm × 12 mm, 0°	06-402-04121

Vista-S 14 mm × 18 mm, 7° Implant Kit 07.02226.401

DESCRIPTION	PART NUMBER
Angled Device, 14 mm × 18 mm × 4 mm, 7°	06-401-05041
Angled Device, 14 mm × 18 mm × 5 mm, 7°	06-401-05051
Angled Device, 14 mm × 18 mm × 6 mm, 7°	06-401-05061
Angled Device, 14 mm × 18 mm × 7 mm, 7°	06-401-05071
Angled Device, 14 mm × 18 mm × 8 mm, 7°	06-401-05081
Angled Device, 14 mm × 18 mm × 9 mm, 7°	06-401-05091
Angled Device, 14 mm × 18 mm × 10 mm, 7°	06-401-05101
Angled Device, 14 mm × 18 mm × 11 mm, 7°	06-401-05111
Angled Device, 14 mm × 18 mm × 12 mm, 7°	06-401-05121

Vista-S 14 mm × 18 mm, 0° Implant Kit 07.02229.401

DESCRIPTION	PART NUMBER
Parallel Device, 14 mm × 18 mm × 4 mm, 0°	06-402-05041
Parallel Device, 14 mm × 18 mm × 5 mm, 0°	06-402-05051
Parallel Device, 14 mm × 18 mm × 6 mm, 0°	06-402-05061
Parallel Device, 14 mm × 18 mm × 7 mm, 0°	06-402-05071
Parallel Device, 14 mm × 18 mm × 8 mm, 0°	06-402-05081
Parallel Device, 14 mm × 18 mm × 9 mm, 0°	06-402-05091
Parallel Device, 14 mm × 18 mm × 10 mm, 0°	06-402-05101
Parallel Device, 14 mm × 18 mm × 11 mm, 0°	06-402-05111
Parallel Device, 14 mm × 18 mm × 12 mm, 0°	06-402-05121

Vista-S 15 mm × 20 mm, 7° Implant Kit 07.02227.401

DESCRIPTION	PART NUMBER
Angled Device, 15 mm × 20 mm × 4 mm, 7°	06-401-06041
Angled Device, 15 mm × 20 mm × 5 mm, 7°	06-401-06051
Angled Device, 15 mm × 20 mm × 6 mm, 7°	06-401-06061
Angled Device, 15 mm × 20 mm × 7 mm, 7°	06-401-06071
Angled Device, 15 mm × 20 mm × 8 mm, 7°	06-401-06081
Angled Device, 15 mm × 20 mm × 9 mm, 7°	06-401-06091
Angled Device, 15 mm × 20 mm × 10 mm, 7°	06-401-06101
Angled Device, 15 mm × 20 mm × 11 mm, 7°	06-401-06111
Angled Device, 15 mm × 20 mm × 12 mm, 7°	06-401-06121

Vista-S 15 mm × 20 mm, 0° Implant Kit 07.02230.401

DESCRIPTION	PART NUMBER
Parallel Device, 15 mm × 20 mm × 4 mm, 0°	06-402-06041
Parallel Device, 15 mm × 20 mm × 5 mm, 0°	06-402-06051
Parallel Device, 15 mm × 20 mm × 6 mm, 0°	06-402-06061
Parallel Device, 15 mm × 20 mm × 7 mm, 0°	06-402-06071
Parallel Device, 15 mm × 20 mm × 8 mm, 0°	06-402-06081
Parallel Device, 15 mm × 20 mm × 9 mm, 0°	06-402-06091
Parallel Device, 15 mm × 20 mm × 10 mm, 0°	06-402-06101
Parallel Device, 15 mm × 20 mm × 11 mm, 0°	06-402-06111
Parallel Device, 15 mm × 20 mm × 12 mm, 0°	06-402-06121

Mergence-S Instrument Kit 96-121-10001

DESCRIPTION	PART NUMBER	DESCRIPTION	PART NUMBER
Central Rotating Inserter	96-106-30001	Angled Provisional, 11 mm × 11 mm × 5 mm	96-101-01051
Lateral Grasping Inserter	96-106-00001	Angled Provisional, 11 mm × 11 mm × 6 mm	96-101-01061
CSG Inserter	07.00558.001	Angled Provisional, 11 mm × 11 mm × 7 mm	96-101-01071
General Tamp	96-105-00002	Angled Provisional, 11 mm × 11 mm × 8 mm	96-101-01081
Central Tamp	96-105-10001	Angled Provisional, 11 mm × 11 mm × 9 mm	96-101-01091
Corner Tamp	96-105-20001	Angled Provisional, 11 mm × 11 mm × 10 mm	96-101-01101
Starter Rasp, 11 mm × 11 mm	96-108-01001	Parallel Provisional, 11 mm × 11 mm × 5 mm	96-102-01051
Angled Rasp, 11 mm × 11 mm × 5 mm	96-108-17051	Parallel Provisional, 11 mm × 11 mm × 6 mm	96-102-01061
Angled Rasp, 11 mm × 11 mm × 6 mm	96-108-17061	Parallel Provisional, 11 mm × 11 mm × 7 mm	96-102-01071
Angled Rasp, 11 mm × 11 mm × 7 mm	96-108-17071	Parallel Provisional, 11 mm × 11 mm × 8 mm	96-102-01081
Angled Rasp, 11 mm × 11 mm × 8 mm	96-108-17081	Parallel Provisional, 11 mm × 11 mm × 9 mm	96-102-01091
Angled Rasp, 11 mm × 11 mm × 9 mm	96-108-17091	Parallel Provisional, 11 mm × 11 mm × 10 mm	96-102-01101
Angled Rasp, 11 mm × 11 mm × 10 mm	96-108-17101	Angled Provisional, 11 mm × 14 mm × 5 mm	96-101-02051
Parallel Rasp, 11 mm × 11 mm × 5 mm	96-108-10051	Angled Provisional, 11 mm × 14 mm × 6 mm	96-101-02061
Parallel Rasp, 11 mm × 11 mm × 6 mm	96-108-10061	Angled Provisional, 11 mm × 14 mm × 7 mm	96-101-02071
Parallel Rasp, 11 mm × 11 mm × 7 mm	96-108-10071	Angled Provisional, 11 mm × 14 mm × 8 mm	96-101-02081
Parallel Rasp, 11 mm × 11 mm × 8 mm	96-108-10081	Angled Provisional, 11 mm × 14 mm × 9 mm	96-101-02091
Parallel Rasp, 11 mm × 11 mm × 9 mm	96-108-10091	Angled Provisional, 11 mm × 14 mm × 10 mm	96-101-02101
Parallel Rasp, 11 mm × 11 mm × 10 mm	96-108-10101	Parallel Provisional, 11 mm × 14 mm × 5 mm	96-102-02051
Starter Rasp, 11 mm × 14 mm	96-108-02001	Parallel Provisional, 11 mm × 14 mm × 6 mm	96-102-02061
Angled Rasp, 11 mm × 14 mm × 5 mm	96-108-27051	Parallel Provisional, 11 mm × 14 mm × 7 mm	96-102-02071
Angled Rasp, 11 mm × 14 mm × 6 mm	96-108-27061	Parallel Provisional, 11 mm × 14 mm × 8 mm	96-102-02081
Angled Rasp, 11 mm × 14 mm × 7 mm	96-108-27071	Parallel Provisional, 11 mm × 14 mm × 9 mm	96-102-02091
Angled Rasp, 11 mm × 14 mm × 8 mm	96-108-27081	Parallel Provisional, 11 mm × 14 mm × 10 mm	96-102-02101
Angled Rasp, 11 mm × 14 mm × 9 mm	96-108-27091		
Angled Rasp, 11 mm × 14 mm × 10 mm	96-108-27101		
Parallel Rasp, 11 mm × 14 mm × 5 mm	96-108-20051		
Parallel Rasp, 11 mm × 14 mm × 6 mm	96-108-20061		
Parallel Rasp, 11 mm × 14 mm × 7 mm	96-108-20071		
Parallel Rasp, 11 mm × 14 mm × 8 mm	96-108-20081		
Parallel Rasp, 11 mm × 14 mm × 9 mm	96-108-20091		
Parallel Rasp, 11 mm × 14 mm × 10 mm	96-108-20101		



KIT CONTENTS (Continued)

Mergence-S Instrument Kit 14 mm × 14 mm 96-261-20001

DESCRIPTION	PART NUMBER
Starter Rasp, 14 mm × 14 mm	96-108-03001
Angled Rasp, 14 mm × 14 mm × 5 mm	96-108-37051
Angled Rasp, 14 mm × 14 mm × 6 mm	96-108-37061
Angled Rasp, 14 mm × 14 mm × 7 mm	96-108-37071
Angled Rasp, 14 mm × 14 mm × 8 mm	96-108-37081
Angled Rasp, 14 mm × 14 mm × 9 mm	96-108-37091
Angled Rasp, 14 mm × 14 mm × 10 mm	96-108-37101
Parallel Rasp, 14 mm × 14 mm × 5 mm	96-108-30051
Parallel Rasp, 14 mm × 14 mm × 6 mm	96-108-30061
Parallel Rasp, 14 mm × 14 mm × 7 mm	96-108-30071
Parallel Rasp, 14 mm × 14 mm × 8 mm	96-108-30081
Parallel Rasp, 14 mm × 14 mm × 9 mm	96-108-30091
Parallel Rasp, 14 mm × 14 mm × 10 mm	96-108-30101



DESCRIPTION	PART NUMBER
Angled Provisional, 11 mm × 11 mm × 4 mm	96-101-01041
Angled Provisional, 11 mm × 11 mm × 11 mm	96-101-01111
Angled Provisional, 11 mm × 11 mm × 12 mm	96-101-01121
Angled Provisional, 11 mm × 14 mm × 4 mm	96-101-02041
Angled Provisional, 11 mm × 14 mm × 11 mm	96-101-02111
Angled Provisional, 11 mm × 14 mm × 12 mm	96-101-02121
Angled Provisional, 14 mm × 14 mm × 4 mm	96-101-03041
Angled Provisional, 14 mm × 14 mm × 11 mm	96-101-03111
Angled Provisional, 14 mm × 14 mm × 12 mm	96-101-03121
Parallel Provisional, 11 mm × 11 mm × 4 mm	96-102-01041
Parallel Provisional, 11 mm × 11 mm × 11 mm	96-102-01111
Parallel Provisional, 11 mm × 11 mm × 12 mm	96-102-01121
Parallel Provisional, 11 mm × 14 mm × 4 mm	96-102-02041
Parallel Provisional, 11 mm × 14 mm × 11 mm	96-102-02111
Parallel Provisional, 11 mm × 14 mm × 12 mm	96-102-02121
Parallel Provisional, 14 mm × 14 mm × 4 mm	96-102-03041
Parallel Provisional, 14 mm × 14 mm × 11 mm	96-102-03111
Parallel Provisional, 14 mm × 14 mm × 12 mm	96-102-03121



Mergence-S Instrument Kit 4 mm, 11 mm, 12 mm Heights 96-261-30001

DESCRIPTION	PART NUMBER
Parallel Bone Rasp, 11 mm × 11 mm × 4 mm	96-108-10041
Parallel Bone Rasp, 11 mm × 11 mm × 11 mm	96-108-10111
Parallel Bone Rasp, 11 mm × 11 mm × 12 mm	96-108-10121
Parallel Bone Rasp, 11 mm × 14 mm × 4 mm	96-108-20041
Parallel Bone Rasp, 11 mm × 14 mm × 11 mm	96-108-20111
Parallel Bone Rasp, 11 mm × 14 mm × 12 mm	96-108-20121
Parallel Bone Rasp, 14 mm × 14 mm × 4 mm	96-108-30041
Parallel Bone Rasp, 14 mm × 14 mm × 11 mm	96-108-30111
Parallel Bone Rasp, 14 mm × 14 mm × 12 mm	96-108-30121
Angled Bone Rasp, 11 mm × 11 mm × 4 mm	96-108-17041
Angled Bone Rasp, 11 mm × 11 mm × 11 mm	96-108-17111
Angled Bone Rasp, 11 mm × 11 mm × 12 mm	96-108-17121
Angled Bone Rasp, 11 mm × 14 mm × 4 mm	96-108-27041
Angled Bone Rasp, 11 mm × 14 mm × 11 mm	96-108-27111
Angled Bone Rasp, 11 mm × 14 mm × 12 mm	96-108-27121
Angled Bone Rasp, 14 mm × 14 mm × 4 mm	96-108-37041
Angled Bone Rasp, 14 mm × 14 mm × 11 mm	96-108-37111
Angled Bone Rasp, 14 mm × 14 mm × 12 mm	96-108-37121



DESCRIPTION	PART NUMBER
Angled Provisional, 14 mm × 14 mm × 5 mm	96-101-03051
Angled Provisional, 14 mm × 14 mm × 6 mm	96-101-03061
Angled Provisional, 14 mm × 14 mm × 7 mm	96-101-03071
Angled Provisional, 14 mm × 14 mm × 8 mm	96-101-03081
Angled Provisional, 14 mm × 14 mm × 9 mm	96-101-03091
Angled Provisional, 14 mm × 14 mm × 10 mm	96-101-03101
Parallel Provisional, 14 mm × 14 mm × 5 mm	96-102-03051
Parallel Provisional, 14 mm × 14 mm × 6 mm	96-102-03061
Parallel Provisional, 14 mm × 14 mm × 7 mm	96-102-03071
Parallel Provisional, 14 mm × 14 mm × 8 mm	96-102-03081
Parallel Provisional, 14 mm × 14 mm × 9 mm	96-102-03091
Parallel Provisional, 14 mm × 14 mm × 10 mm	96-102-03101



**Vista-S Extended Footprint Basic Instrument Kit
07-02231-401
13 mm × 16 mm and 14 mm × 18 mm**

DESCRIPTION	QTY	PART NUMBER
Parallel Bone Rasp, 13 mm × 16 mm × 4 mm	1	96-108-40041
Parallel Bone Rasp, 14 mm × 18 mm × 4 mm	1	96-108-50041
General Tamp	1	96-105-00002
Central Tamp	1	96-105-10001
Central Rotating Inserter	1	96-106-30001



DESCRIPTION	QTY	PART NUMBER
Angled Provisional, 13 mm × 16 mm × 4 mm	1	96-101-04041
Angled Provisional, 13 mm × 16 mm × 5 mm	1	96-101-04051
Angled Provisional, 13 mm × 16 mm × 6 mm	1	96-101-04061
Angled Provisional, 13 mm × 16 mm × 7 mm	1	96-101-04071
Angled Provisional, 13 mm × 16 mm × 8 mm	1	96-101-04081
Angled Provisional, 13 mm × 16 mm × 9 mm	1	96-101-04091
Angled Provisional, 13 mm × 16 mm × 10 mm	1	96-101-04101
Angled Provisional, 13 mm × 16 mm × 11 mm	1	96-101-04111
Angled Provisional, 13 mm × 16 mm × 12 mm	1	96-101-04121
Angled Provisional, 14 mm × 18 mm × 4 mm	1	96-101-05041
Angled Provisional, 14 mm × 18 mm × 5 mm	1	96-101-05051
Angled Provisional, 14 mm × 18 mm × 6 mm	1	96-101-05061
Angled Provisional, 14 mm × 18 mm × 7 mm	1	96-101-05071
Angled Provisional, 14 mm × 18 mm × 8 mm	1	96-101-05081
Angled Provisional, 14 mm × 18 mm × 9 mm	1	96-101-05091
Angled Provisional, 14 mm × 18 mm × 10 mm	1	96-101-05101
Angled Provisional, 14 mm × 18 mm × 11 mm	1	96-101-05111
Angled Provisional, 14 mm × 18 mm × 12 mm	1	96-101-05121
Parallel Provisional, 13 mm × 16 mm × 4 mm	1	96-102-04041
Parallel Provisional, 13 mm × 16 mm × 5 mm	1	96-102-04051
Parallel Provisional, 13 mm × 16 mm × 6 mm	1	96-102-04061
Parallel Provisional, 13 mm × 16 mm × 7 mm	1	96-102-04071
Parallel Provisional, 13 mm × 16 mm × 8 mm	1	96-102-04081
Parallel Provisional, 13 mm × 16 mm × 9 mm	1	96-102-04091
Parallel Provisional, 13 mm × 16 mm × 10 mm	1	96-102-04101
Parallel Provisional, 13 mm × 16 mm × 11 mm	1	96-102-04111
Parallel Provisional, 13 mm × 16 mm × 12 mm	1	96-102-04121



**Vista-S Extended Footprint Basic Instrument Kit
07-02231-401
13 mm × 16 mm and 14 mm × 18 mm (Continued)**

DESCRIPTION	QTY	PART NUMBER
Parallel Provisional, 14 mm × 18 mm × 4 mm	1	96-102-05041
Parallel Provisional, 14 mm × 18 mm × 5 mm	1	96-102-05051
Parallel Provisional, 14 mm × 18 mm × 6 mm	1	96-102-05061
Parallel Provisional, 14 mm × 18 mm × 7 mm	1	96-102-05071
Parallel Provisional, 14 mm × 18 mm × 8 mm	1	96-102-05081
Parallel Provisional, 14 mm × 18 mm × 9 mm	1	96-102-05091
Parallel Provisional, 14 mm × 18 mm × 10 mm	1	96-102-05101
Parallel Provisional, 14 mm × 18 mm × 11 mm	1	96-102-05111
Parallel Provisional, 14 mm × 18 mm × 12 mm	1	96-102-05121



KIT CONTENTS (Continued)

Mergence-S Rasp Auxiliary Kit 13 mm × 16 mm and 14 mm × 18 mm 07-02232-401

DESCRIPTION	QTY	PART NUMBER
Angled Bone Rasp, 13 mm × 16 mm × 4 mm	1	96-108-47041
Angled Bone Rasp, 13 mm × 16 mm × 5 mm	1	96-108-47051
Angled Bone Rasp, 13 mm × 16 mm × 6 mm	1	96-108-47061
Angled Bone Rasp, 13 mm × 16 mm × 7 mm	1	96-108-47071
Angled Bone Rasp, 13 mm × 16 mm × 8 mm	1	96-108-47081
Angled Bone Rasp, 13 mm × 16 mm × 9 mm	1	96-108-47091
Angled Bone Rasp, 13 mm × 16 mm × 10 mm	1	96-108-47101
Angled Bone Rasp, 13 mm × 16 mm × 11 mm	1	96-108-47111
Angled Bone Rasp, 13 mm × 16 mm × 12 mm	1	96-108-47121
Angled Bone Rasp, 14 mm × 18 mm × 4 mm	1	96-108-57041
Angled Bone Rasp, 14 mm × 18 mm × 5 mm	1	96-108-57051
Angled Bone Rasp, 14 mm × 18 mm × 6 mm	1	96-108-57061
Angled Bone Rasp, 14 mm × 18 mm × 7 mm	1	96-108-57071
Angled Bone Rasp, 14 mm × 18 mm × 8 mm	1	96-108-57081
Angled Bone Rasp, 14 mm × 18 mm × 9 mm	1	96-108-57091
Angled Bone Rasp, 14 mm × 18 mm × 10 mm	1	96-108-57101
Angled Bone Rasp, 14 mm × 18 mm × 11 mm	1	96-108-57111
Angled Bone Rasp, 14 mm × 18 mm × 12 mm	1	96-108-57121
Parallel Bone Rasp, 13 mm × 16 mm × 5 mm	1	96-108-40051
Parallel Bone Rasp, 13 mm × 16 mm × 6 mm	1	96-108-40061
Parallel Bone Rasp, 13 mm × 16 mm × 7 mm	1	96-108-40071
Parallel Bone Rasp, 13 mm × 16 mm × 8 mm	1	96-108-40081
Parallel Bone Rasp, 13 mm × 16 mm × 9 mm	1	96-108-40091
Parallel Bone Rasp, 13 mm × 16 mm × 10 mm	1	96-108-40101
Parallel Bone Rasp, 13 mm × 16 mm × 11 mm	1	96-108-40111
Parallel Bone Rasp, 13 mm × 16 mm × 12 mm	1	96-108-40121
Parallel Bone Rasp, 14 mm × 18 mm × 5 mm	1	96-108-50051
Parallel Bone Rasp, 14 mm × 18 mm × 6 mm	1	96-108-50061
Parallel Bone Rasp, 14 mm × 18 mm × 7 mm	1	96-108-50071
Parallel Bone Rasp, 14 mm × 18 mm × 8 mm	1	96-108-50081
Parallel Bone Rasp, 14 mm × 18 mm × 9 mm	1	96-108-50091
Parallel Bone Rasp, 14 mm × 18 mm × 10 mm	1	96-108-50101
Parallel Bone Rasp, 14 mm × 18 mm × 11 mm	1	96-108-50111
Parallel Bone Rasp, 14 mm × 18 mm × 12 mm	1	96-108-50121



Mergence-S Rasp and Provisional Kit 15 mm × 20 mm 07-02233-401

DESCRIPTION	QTY	PART NUMBER
Parallel Bone Rasp, 15 mm × 20 mm × 4 mm	1	96-108-60041
Parallel Bone Rasp, 15 mm × 20 mm × 5 mm	1	96-108-60051
Parallel Bone Rasp, 15 mm × 20 mm × 6 mm	1	96-108-60061
Parallel Bone Rasp, 15 mm × 20 mm × 7 mm	1	96-108-60071
Parallel Bone Rasp, 15 mm × 20 mm × 8 mm	1	96-108-60081
Parallel Bone Rasp, 15 mm × 20 mm × 9 mm	1	96-108-60091
Parallel Bone Rasp, 15 mm × 20 mm × 10 mm	1	96-108-60101
Parallel Bone Rasp, 15 mm × 20 mm × 11 mm	1	96-108-60111
Parallel Bone Rasp, 15 mm × 20 mm × 12 mm	1	96-108-60121
Angled Bone Rasp, 15 mm × 20 mm × 4 mm	1	96-108-67041
Angled Bone Rasp, 15 mm × 20 mm × 5 mm	1	96-108-67051
Angled Bone Rasp, 15 mm × 20 mm × 6 mm	1	96-108-67061
Angled Bone Rasp, 15 mm × 20 mm × 7 mm	1	96-108-67071
Angled Bone Rasp, 15 mm × 20 mm × 8 mm	1	96-108-67081
Angled Bone Rasp, 15 mm × 20 mm × 9 mm	1	96-108-67091
Angled Bone Rasp, 15 mm × 20 mm × 10 mm	1	96-108-67101
Angled Bone Rasp, 15 mm × 20 mm × 11 mm	1	96-108-67111
Angled Bone Rasp, 15 mm × 20 mm × 12 mm	1	96-108-67121



Parallel Provisional, 15 mm × 20 mm × 4 mm	1	96-102-06041
Parallel Provisional, 15 mm × 20 mm × 5 mm	1	96-102-06051
Parallel Provisional, 15 mm × 20 mm × 6 mm	1	96-102-06061
Parallel Provisional, 15 mm × 20 mm × 7 mm	1	96-102-06071
Parallel Provisional, 15 mm × 20 mm × 8 mm	1	96-102-06081
Parallel Provisional, 15 mm × 20 mm × 9 mm	1	96-102-06091
Parallel Provisional, 15 mm × 20 mm × 10 mm	1	96-102-06101
Parallel Provisional, 15 mm × 20 mm × 11 mm	1	96-102-06111
Parallel Provisional, 15 mm × 20 mm × 12 mm	1	96-102-06121
Angled Provisional, 15 mm × 20 mm × 4 mm	1	96-101-06041
Angled Provisional, 15 mm × 20 mm × 5 mm	1	96-101-06051
Angled Provisional, 15 mm × 20 mm × 6 mm	1	96-101-06061
Angled Provisional, 15 mm × 20 mm × 7 mm	1	96-101-06071
Angled Provisional, 15 mm × 20 mm × 8 mm	1	96-101-06081
Angled Provisional, 15 mm × 20 mm × 9 mm	1	96-101-06091
Angled Provisional, 15 mm × 20 mm × 10 mm	1	96-101-06101
Angled Provisional, 15 mm × 20 mm × 11 mm	1	96-101-06111
Angled Provisional, 15 mm × 20 mm × 12 mm	1	96-101-06121



IMPORTANT INFORMATION ON THE VISTA-S FUSION DEVICE

Description

The Vista-S Device is manufactured wholly from unfilled PEEK-OPTIMA LT1, a polyetheretherketone. This material is a thermoplastic polycondensate, semicrystalline polymer. It is used in this device in the unfilled state (i.e., no glass or carbon fiber fill). Due to the radiolucent nature of PEEK-OPTIMA LT1, three radiopaque markers made of tantalum are incorporated into the device to indicate the nose end and the superior and inferior corners of the opposite end for use in postoperative monitoring of device position.

The superior and inferior surfaces of the device have a textured surface to provide increased stability. The device is available in a variety of cross-sectional geometries and sizes. These implants offer two different included angle options to maintain the natural contour of the spine. These implants are intended for single use only and must not be reused under any circumstances. Surgical instruments are also available to assist in the implantation of the device.

Indications

The Vista-S Fusion Device is intended for use in skeletally mature patients with degenerative disc disease (DDD) with/without radicular symptoms at one level from C2–T1. DDD is defined as discogenic pain with degeneration of the disc confirmed by history and radiographic studies. These patients should have had six weeks of non-operative treatment. The Vista-S Device is intended for use with supplemental spinal fixation systems and with autogenous bone graft. The Vista-S Fusion Device is implanted via an anterior approach.

Contraindications

- Active local infection in or near the operative region.
- Active systemic infection and/or disease.
- Severe osteoporosis or insufficient bone density, which in the medical opinion of the physician precludes surgery or contraindicates instrumentation.
- Prior surgical procedure using the desired operative approach.
- Spinal conditions other than cervical DDD.
- Current metastatic tumors of the vertebrae adjacent to the implant.

- Known or suspected sensitivity to the implant materials.
- Endocrine or metabolic disorders known to affect osteogenesis (e.g., Paget disease, renal osteodystrophy, hypothyroidism).
- Systemic disease that requires the chronic administration of nonsteroidal anti-inflammatory or steroidal drugs.
- Significant mental disorder or condition that could compromise the patient's ability to remember and comply with preoperative and postoperative instructions (e.g., current treatment for a psychiatric/psychosocial disorder, senile dementia, Alzheimer's disease, traumatic head injury).
- Neuromuscular disorder that would engender unacceptable risk of instability, implant fixation failure or complications in postoperative care. Neuromuscular disorders include spina bifida, cerebral palsy and multiple sclerosis.
- Pregnancy.
- Patients unwilling to follow postoperative instructions, especially those in athletic and occupational activities.
- Morbid obesity.
- Symptomatic cardiac disease.
- Skeletal immaturity.
- Grossly distorted anatomy.
- Conditions other than those indicated.

IMPORTANT INFORMATION ON THE VISTA-S FUSION DEVICE (*Continued*)

Warnings

- Surgery is not always successful. Preoperative symptoms may not be relieved or may worsen. Surgical knowledge of the procedure and the device are important, as is patient selection. Patient compliance is also important. Tobacco and alcohol abuse may lead to unsuccessful results.
- Appropriate device selection is crucial to obtain proper fit and to decrease the stress placed on the implant.
- Delayed healing can lead to fracture or breakage of the implants due to increased stress and material fatigue. Patients must be fully informed of all the risks associated with the implant and the importance of following postoperative instructions regarding weight bearing and activity levels to facilitate proper bone growth and healing.
- The implant must be handled carefully following manufacturer's instructions to prevent damage to the implant.
- Implants must not be modified or otherwise processed in any way.
- Once a device has been implanted, it must never be reused. If the package is damaged, opened, or if the expiration date has passed, but the device is not used, the device must be returned to Zimmer Biomet Spine. The device must not be re-sterilized by the end user.
- Results may be worse with multilevel disease. Supplemental fixation is required. The surgeon must be familiar with fixation techniques and appropriate hardware.
- The surgeon must be familiar with the appropriate technique to implant the supplemental internal fixation and the appropriate hardware.
- MRI Compatibility
 - The patient must be told that implants can affect the results of computer tomography (CT) or magnetic resonance imaging (MRI) scans.
 - The Vista-S Device has not been evaluated for safety or compatibility in the MR environment.
 - The Vista-S Device has not been tested for heating or migration in the MR environment.
- The surgeon must have a thorough knowledge of the mechanical and material limitations of semicrystalline polymeric surgical implants and be thoroughly familiar with the surgical technique for implanting the Vista-S Device for the given Indications for Use.
- The surgeon should be familiar with the various devices and instruments and verify that all are available before beginning the surgery. Additionally, the packaging and implant should be inspected for damage prior to implantation.
- In the event that removal of the implant is considered (e.g., due to loosening, fracture, migration of the implant; infection; increased pain, etc.), the risks versus benefits must be carefully weighed. Such events can occur even after healing, especially in more active patients. Appropriate postoperative care must be given following implant removal to avoid further complication.
- The surgeon must be thoroughly familiar with the options for supplemental internal fixation systems and the associated surgical techniques.
- Implants must be fully seated within the inserter prior to use. Care must be taken not to over-tighten the implant inserter assembly. Additionally, care must be taken not to manipulate the inserter implant interface in a way not recommended by the surgical technique.
- The surgeon must ensure the implant is properly seated prior to closing of the soft tissue.
- Extreme caution must be used around the spinal cord, nerve roots and blood vessels.

Surgeon Precautions

- The implantation of an intervertebral body fusion device should be performed only by experienced spinal surgeons with specific training in the use of this device because this is a technically demanding procedure presenting a risk of serious injury to the patient.
- Based on fatigue testing results, the physician/surgeon should consider the levels of implantation, patient weight, patient activity level, other patient conditions, etc. which may impact on the performance of the system.

Patient Precautions

- Postoperative care instructions are extremely important and must be followed carefully. Noncompliance with postoperative care instructions could lead to failure of the device, and the possibility of additional surgery to remove the device.
- The patient should limit activities that result in overhead lifting, repetitive neck bending (especially neck extension) and heavy lifting until a physician determines solid bony fusion is achieved.
- An orthotic brace may be worn following surgery for support. The attending physician, based upon each patient's clinical progress, will determine whether a brace is appropriate and, if necessary, the length of time the brace is prescribed.
- Non-steroidal anti-inflammatory and steroidal drugs should be avoided for at least 45 days, or as directed by a physician, postoperatively.

Disclaimer: This document is intended exclusively for physicians and is not intended for laypersons. Information on the products and procedures contained in this document is of a general nature and does not represent and does not constitute medical advice or recommendations. Because this information does not purport to constitute any diagnostic or therapeutic statement with regard to any individual medical case, each patient must be examined and advised individually, and this document does not replace the need for such examination and/or advice in whole or in part.



Caution: Federal (USA) law restricts this device to sale by or on the order of a physician. Rx only. Please see the product Instructions for Use for a complete listing of the indications, contraindications, precautions, warnings and adverse effects.

The CE mark is valid only if it is also printed on the product label.



Manufactured by:

Zimmer Trabecular
Metal Technology, Inc.
10 Pomeroy Rd.
Parsippany, NJ 07054
+1 201.818.1800



Zimmer GmbH
Sulzerallee 8
CH-8404 Winterthur
Switzerland
+41 058.854.80.00

Distributed by:

Zimmer Biomet Spine, Inc.
10225 Westmoor Dr.
Westminster, CO 80021 USA
+1 800.447.3625



ZIMMER BIOMET
Your progress. Our promise.®

800.447.3625/zimmerbiomet.com

©2020 Zimmer Biomet Spine, Inc. All rights reserved.

All content herein is protected by copyright, trademarks and other intellectual property rights, as applicable, owned by or licensed to Zimmer Biomet Spine, Inc. or its affiliates unless otherwise indicated, and must not be redistributed, duplicated or disclosed, in whole or in part, without the express written consent of Zimmer Biomet Spine. This material is intended for health care professionals, the Zimmer Biomet Spine sales force and authorized representatives. Distribution to any other recipient is prohibited. PEEK-OPTIMA® Polymer is a trademark of Invivio Ltd.

0749.2-US-en-REV0420